

# 注塑用机械手 TAKE-OUT ROBOT

## HDW-80



### 标准功能 STANDARD FUNCTION

- 装箱动作 (各轴256点)  
Packaging motion (Max. 256 points)
- 自由装箱点 (115点 × 2处)  
Free packaging motion (115points × 2stage)
- 取出侧前进姿势控制  
Forward and rotate at removing side
- 走行途中姿势  
Posture control during traverse
- 落下测下降途中姿势  
Posture midway descent at release side
- 顶针连动  
Ejector link
- 不良品排出回路  
Defective product reject circuit
- 初期不良品排出回路  
Initial defective product reject circuit
- 取出下降待机  
Delayed arm descent
- 胶口途中开放 (去程, 返程)  
Midway runner release (Move, Revert)
- 水口模内开放  
Runner release within mold
- 吸着确认单元 (2回路)  
Additional vacuum sensing unit (2 circuit)
- 横走行待机  
Delayed traverse
- 滑移取出回路  
Undercut extract circuit
- 输送带启动信号  
Start signal of conveyor
- 内部存储记忆 (最大100种类型)  
Internal memory (for Max 100 molds)
- 设定值锁定功能  
Lock function of setting value
- 固定可动切换  
Extraction from fixed mold
- 2国语言切换 (中文, 英文)  
Two language exchange (Chinese/English)

型式 MODEL	单位 UNIT	HDW-80
电源 Power Source	V	AC 200~220 ± 10% 50/60Hz
最大消费电力 Max Power Consumption	KW	2
使用气压 Air Pressure	Mpa	0.5~0.7
空气消费量 Air Consumption	NI/cycle	2.9
驱动方式 Drive System	---	伺服马达 / AC Servo Motor
姿势 (气缸) Posture (Air Cylinder)	---	90°固定 / 90°Fixed
■ 气缸推力 (气压0.49MPa时) Air Cylinder Driving Force (Air Pressure at 0.49MPa)		
最大可搬重量 Max.Load	Kg	3【含夹具重量 / Incl Chuck Weight】
姿势力矩 Posture Torque	N · m	8.3
■ 行程 Stroke		
主臂上下 Main-arm Vertical	mm	900
副臂上下 Sub-arm Vertical	mm	---
前后(主臂) Crosswise (M)	mm	主臂/M 180 ~ 680
走行 Traverse	mm	1600
■ 本体重量 Net Weight		
本体 Main Body	Kg	279
操作盒 Pendant	Kg	1.6

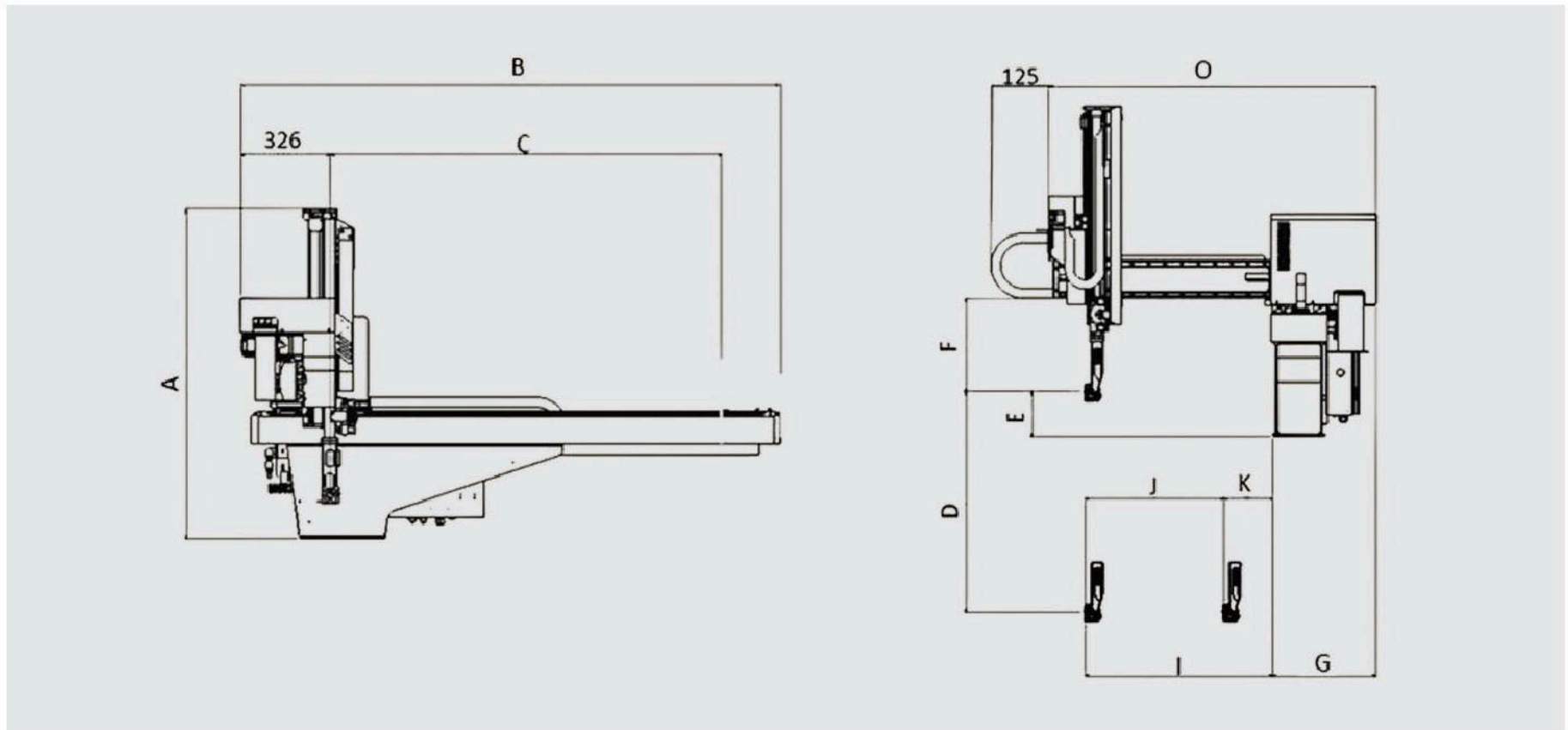

### 外形尺寸 OUTER DIMENSIONS

### HDW-80

A	总高 Overall height	1310mm
B	总长 Overall length	2160mm
C	走行行程 Traverse stroke	1600mm
D	主臂上下行程 Main-arm vertical stroke	900mm
E	主臂上下待机 Main-arm vertical standby	170mm
F	夹具安装有效空间 Bottom of crosswise to chuck mount position	330mm
G	底座里侧面-箱体末端 Base side face-Box end	375mm
H	副臂上下待机 Sub-arm Vertical standby	---
I	主臂前进最大值 Main-arm reach max	680mm
J	主臂前进最大行程 Main-arm crosswise stroke max	500mm
K	主臂前后待机最小值 Main-arm crosswise standby min	180mm
L	主副臂接近最小值 Main/Sub-arm proximity min	---
M	副臂前进最大行程 Sub-arm crosswise stroke max	---
N	副臂前后待机最小值 Sub-arm crosswise standby min	---
O	前后臂末端-箱体末端 Crosswise arm end-Box end	1170mm

### 选项功能 OPTION FUNCTION

- ◆ 夹具内剪刀回路  
Air nipper in chuck circuit
- ◆ NT剪切·可动侧  
NT gate cutting on crossmember of moving
- ◆ 吸着确认2回路  
Additional vacuum sensing unit ( 2 circuits )
- ◆ 制品夹取2回路  
Product gripping 2 circuits
- ◆ 上升途中闭模  
Mold close during ascend
- ◆ 回转单元  
Rotation unit
- ◆ 顶针后退连动  
Ejector return link
- ◆ 欧规12  
EUROMAP12
- ◆ 欧规67  
EUROMAP 67